

Accessories for drilling		B17 Pro	B23 Pro/Vario	B26 Pro/Vario	B33 Pro/Vario	B16 H Vario	B24 H/Vario	B28 H/Vario	B34 H/Vario	B39 B5 Vario	B40 GSP B40 GSM	B50 G5M	RB 35
	Direct quick-action drill chuck 0-8 mm/MT2	305 0582	●	●	—	○	—	●	○	○	○	○	○
	Direct quick-action drill chuck 0-13mm/MT3	305 0585	—	●	●	○	—	—	●	○	●	○	○
	Direct quick-action drill chuck 0-	305 0587	—	—	—	●	—	—	—	●	—	●	—
	Direct quick-action drill chuck 0-8 mm B16	305 0608	●	●	●	●	●	●	●	●	●	●	●
	Precision quick-action drill chuck 0-10 mm B16	305 0610	●	●	●	●	●	●	●	●	●	●	●
	Precision quick-action drill chuck 0-13 mm B16	305 0623	●	●	●	●	●	●	●	●	●	●	●
	Precision quick-action drill chuck 0-16 mm B16	305 0626	●	●	●	●	—	●	●	●	●	●	—
	Rohm quick-action drill chuck 1-13 mm, B 16	305 0656	●	●	●	●	●	●	●	●	●	●	●
	Rohm quick-action drill chuck 3-16 mm, B	305 0657	●	●	●	●	●	●	●	●	●	●	●
	Reducing bushes MT3-MT2	305 0663	—	—	●	—	—	—	●	—	●	—	—
	Reducing bushes MT4-MT3	305 0664	—	—	—	●	—	—	—	●	—	●	—
	Reducing bushes MT4- MT2	305 0665	—	—	—	●	—	—	—	●	—	●	—
	Morse taper MT2 - B16	305 0659	●	●	—	—	—	●	—	—	—	—	—
	Morse taper MT3 - B16	305 0660	—	—	●	—	—	—	●	—	●	—	●
	Morse taper MT4 - B16	305 0661	—	—	—	●	—	—	—	●	—	●	—
	Morse taper MT5 - B16	305 0675	—	—	—	—	—	—	—	—	—	—	—
	Morse taper MT6 - B16	305 0676	—	—	—	—	—	—	—	—	—	—	—
	Titanium twist drill kit 13 mm	305 1010	●	●	●	●	●	●	●	●	●	●	●
	Twist drills HSS / MT2	305 1002	●	●	○	○	—	●	○	○	○	○	○
	Twist drills HSS / MT3	305 1003	—	●	●	○	—	—	●	●	○	○	●
	Threading attachment M5-M12	335 2042	○	●	●	○	●	●	●	●	●	●	●
	Taper drift MSP1	305 0636	●	●	●	—	—	●	●	—	●	—	●
	Taper drift MSP2	305 0637	—	—	—	●	—	—	—	●	—	●	—
	Clamping tool kit SPW 8	335 2015	—	—	—	—	—	—	—	—	—	—	—
	Clamping tool kit SPW 10	335 2016	●	●	—	—	●	—	—	—	—	—	—
	Clamping tool kit SPW 12	335 2017	—	—	●	●	—	●	●	●	—	—	—
	Clamping tool kit SPW 14	335 2018	—	—	—	—	—	—	—	—	—	—	●
	Clamping tool kit SPW 16	335 2019	—	—	—	—	—	—	—	—	●	●	—
	Universal coolant equipment 230 V	335 2002	●	●	●	●	●	●	●	●	○	○	○
	Universal coolant equipment 400 V	335 2001	—	●	●	●	—	●	●	●	●	●	●
	Coolant lubricant sprayer MMC 1	335 6663	●	●	●	●	●	●	●	●	●	●	●
	Coolant hose KMS 2	335 6660	●	●	●	●	●	●	●	●	●	●	●
	Machine vice MSO 75	300 0075	●	●	●	●	●	●	●	●	○	○	○
	Machine vice MSO 100	300 0100	●	●	●	●	●	●	●	○	○	○	○
	Machine vice MSO 125	300 0125	●	●	●	●	●	●	●	○	○	○	○
	Machine vice MSO 150	300 0150	●	●	●	○	●	●	●	○	○	○	○
	Machine vice BMS 85	300 0008	●	●	●	●	●	●	●	○	○	○	○
	Machine vice BMS 100	300 0010	●	●	●	●	●	●	●	○	○	○	○
	Machine vice BMS 120	300 0012	●	●	●	●	●	●	●	○	○	○	○
	Machine vice BMS 150	300 0015	●	●	●	○	●	●	●	○	○	○	○
	Machine vice BMS 200	300 0020	○	○	○	○	—	○	○	○	●	●	●
	Machine vice BSI 100	300 0210	●	●	●	●	●	●	●	●	○	○	○
	Machine vice BSI 140	300 0214	○	○	○	○	○	○	○	○	○	○	○
	Machine vice BSI 200	300 0220	—	—	—	—	—	○	—	○	●	●	●

● Recommended ○ Partly recommended — Not recommended

This table of accessories includes all recommended options of accessories. Depending on the individual case it may however be practical to use other accessories.

Machine vices MSO with prismatic jaws

- Smooth running
- Exact jaw guiding, also at high axial load
- Spindle with rolled trapezoid thread
- Multiple possibilities for assembly on the drilling table due to oblong holes

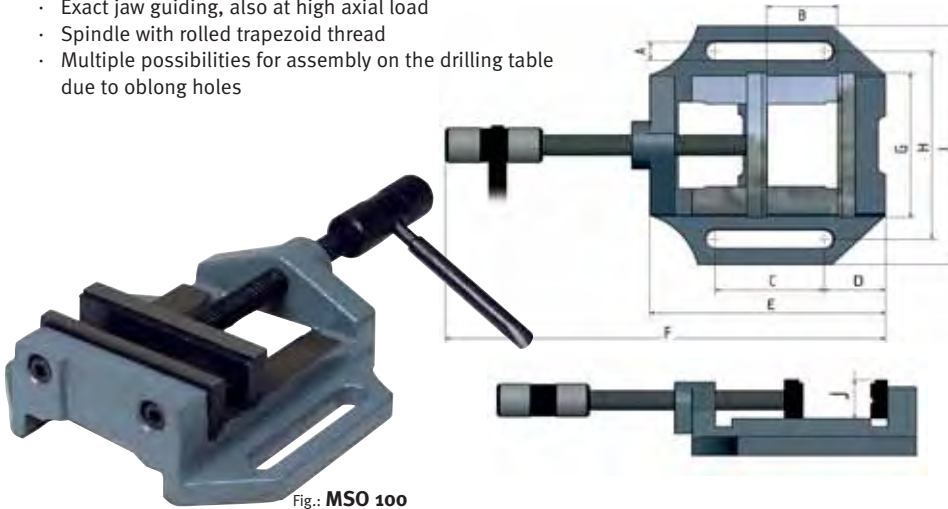

Fig.: MSO 100

Machine vices MSO				
	MSO 75	MSO 100	MSO 125	MSO 150
A	12.5	12.5	12.5	14.5
B	55	90	110	130
C	55	74	80	100
D	30	46	46	56
E	126	165	186	222
F	270	350	400	455
G	75	100	125	150
H	100	130	150	170
I	130	165	182	208
J	28	28	30	35
Item No	300 0075	300 0100	300 0125	300 0150
€ (VAT excl.)	15.90	17.90	21.90	24.90

Machine vices BMS with prismatic jaws

- Robust type with prismatic jaws
- Smooth running
- Exact jaw guiding
- Spindle with rolled trapezoid thread
- Multiple possibilities for assembly on the drilling table due to oblong holes

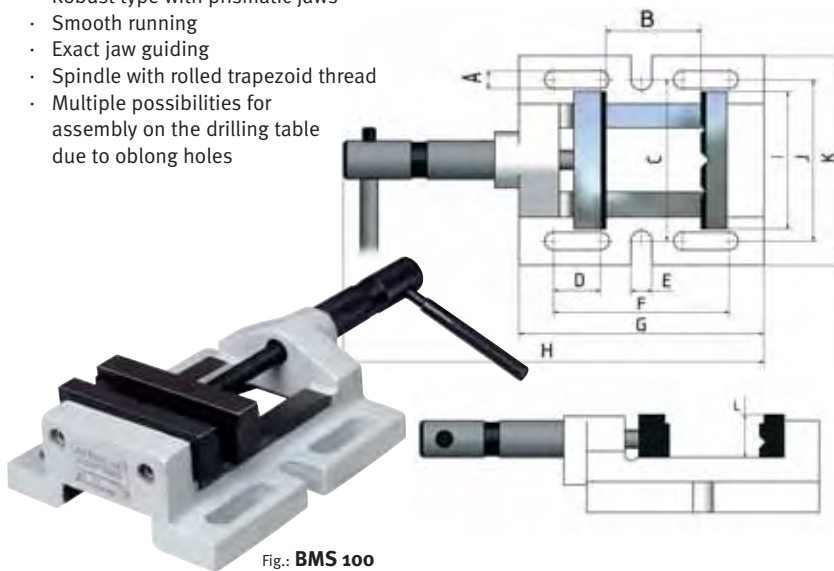

Fig.: BMS 100

Machine vices BMS					
	BMS 85	BMS 100	BMS 120	BMS 150	BMS 200
A	11	12.5	12.5	12.5	12.5
B	70	90	110	130	160
C	100	120	140	172	212
D	29	39	48	82	78
E	13	15	14.5	14.5	13.5
F	109	125	146	180	210
G	152	170	193	228	262
H	260	280	330	375	445
I	85	100	120	150	200
J	100	120	140	170	216
K	130	150	170	200	252
L	27	30	35	45	60
Item No	300 0008	300 0010	300 0012	300 0015	300 0020
€ (VAT excl.)	26.00	36.00	46.00	59.00	79.00

Machine vices BSI

- Drilling machine vices of industrial quality
- Replaceable prismatic jaws
- Long guiding of the movable jaw, thus no tilting
- Multiple possibilities for assembly on the drilling table due to oblong holes
- Prismatic jaws precision ground
- High-grade grey casting
- Scraped guiding surfaces

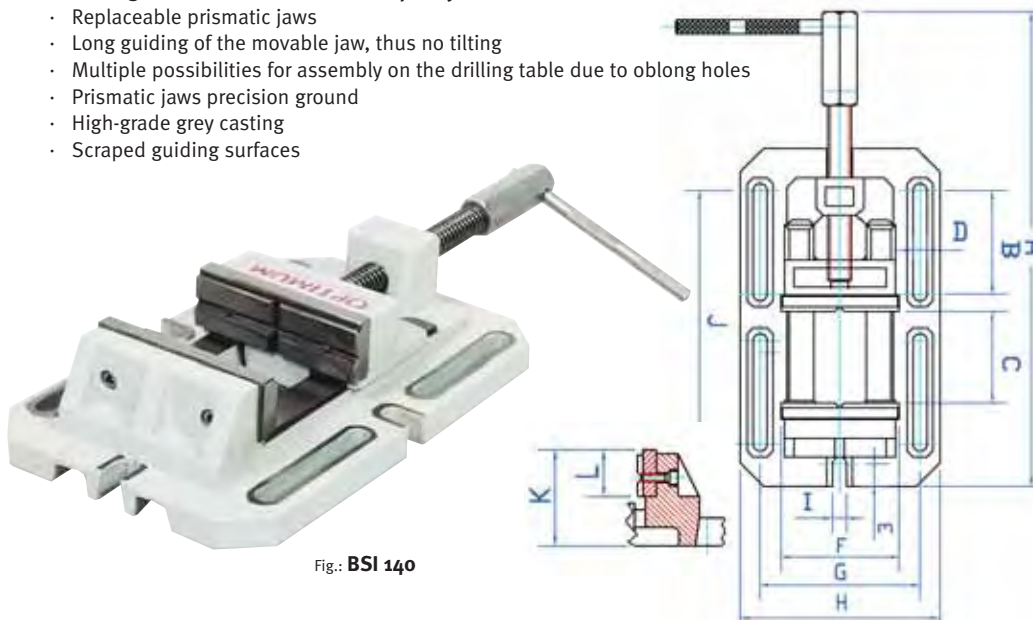

Fig.: BSI 140

Machine vices BSI			
	BSI 100	BSI 140	BSI 200
A	350-460	455-610	578-788
B	88	105	163
C	110	150	200
D	12	14	16
E	19	23	28
F	100	140	200
G	136	189	250
H	170	230	290
I	12	14	14
J	216	290	406
K	72	90	114
L	40	50	64
Weight	8.7	18	35
Item No	300 0210	300 0214	300 0220
€ (VAT excl.)	119.00	169.00	219.00

Twist drill kit 305 1010 **29.50**

- Coated with titanium
- 25 pcs; sizes 1 - 13 mm
- Higher service life and durability
- Higher hardness than hard metal
- More rapid working results
- Low wear
- Metal box



Twist drill HSS with morse taper

- 9 pcs; sizes 14.5/16/18/20/22/24/26/28/30 mm
- Wooden box

Twist drill MT 2 305 1002 **89.00**

Twist drill MT 3 305 1003 **89.00**



OPTIMUM clamping tool kit SPW 58 pcs

- Handy wall unit
- Metric threads
- 24 pcs draw-in bolts
- 6 pcs T-slots
- 6 pcs nuts
- 4 pcs coupling nuts
- 6 pcs step clamps
- 12 pcs step blocks

SPW 8 335 2015 **69.00**

- T-slots (size 10 mm) draw bar thread M 8

SPW 10 335 2016 **75.00**

- T-slots (size 12 mm) draw bar thread M 10

SPW 12 335 2017 **79.00**

- T-slots (size 14 mm) draw bar thread M 12

SPW 14 335 2018 **89.00**

- T-slots (size 16 mm) draw bar thread M 14

SPW 16 335 2019 **99.00**

- T-slots (size 18 mm) draw bar thread M 16



Universal coolant equipment

- Lift max. 2.5 m
- Conveying capacity 8 l/min
- Tank capacity 11 l
- Tank size L x W x H: 370 x 245 x 170 mm
- Complete with tank, flexible tube, hose
- With German switch/plug combination
- Magnetic foot attachment of the coolant hose
- For self-assembly

Universal coolant equipment 230 V 335 2002 **189.00**

Universal coolant equipment 400 V 335 2001 **189.00**



Coolant lubricant sprayer with magnetic stand MMC1335 6663 89,00

- Size of stand L x W x H: 62 x 50 x 55 mm
- Screwed connection for external supply of compressed air
- Adhesion of the magnetic stand 75 kg
- Flexible and stable hose
- Length of the coolant hose 500 mm

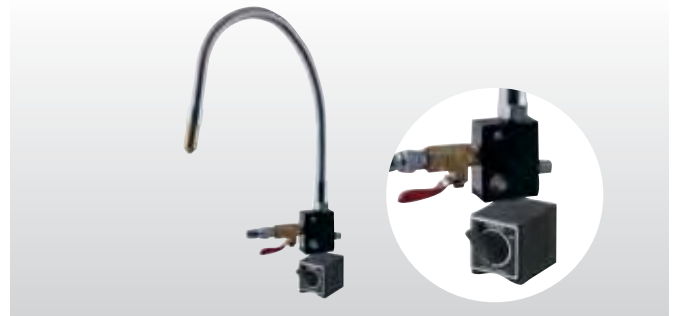

Coolant hose KMS 2 335 6660 **37.00**

- Two variable coolant hoses made of individual plastic elements
- Not electrically conductive
- Adhesion of the magnetic stand up to 50 kg
- Length of the coolant hoses 335 mm
- Flexible and stable
- Insensitive to most solvents and chemicals
- Universally applicable on all machine tools

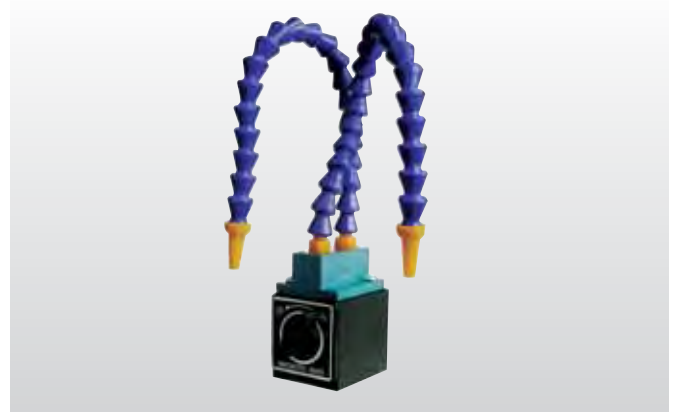

DRILLING ACCESSORIES

Direct quick-action drill chuck

- Concentricity precision better than 0.05 mm

o - 8 mm	305 0582	69.00
· with direct holding fixture MT2		
o - 13 mm	305 0585	89.00
· with direct holding fixture MT3		
o - 13 mm	305 0587	95.00
· with direct holding fixture MT4		



OPTIMUM Precision quick-action drill chuck

- Concentricity precision better than 0.06 mm

o - 8 mm; B16	305 0608	25.00
o - 10 mm; B16	305 0610	29.00
o - 13 mm; B16	305 0623	31.00
o - 16 mm; B16	305 0626	39.00



RÖHM quick-action drill chuck

1 - 13 mm; B 16	305 0656	45.00
3 - 16 mm; B 16	305 0657	49.00



Taper drift

MSP 1	305 0636	22.00
· for MT 1 - MT 3		
MSP 2	305 0637	27.00
· for MT 4 - MT 6		



Reducing bushes

MT 3 - MT 2	305 0663	7.50
MT 4 - MT 3	305 0664	12.00
MT 4 - MT 2	305 0665	11.90

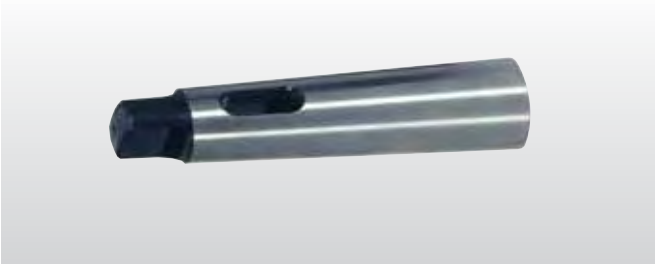

Morse taper

MT 2 - B16	305 0659	4.90
MT 3 - B16	305 0660	7.90
MT 4 - B16	305 0661	12.90
MT 5 - B16	305 0675	15.90
MT 6 - B16	305 0676	19.90

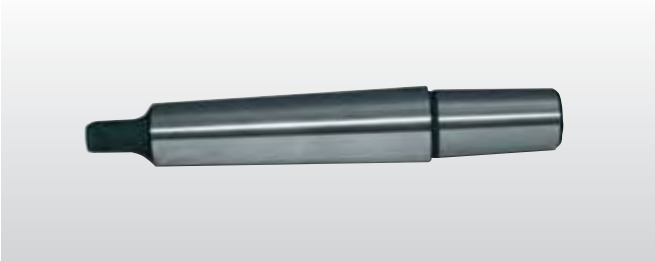

Extension bushes

MT 2 - MT 3	305 0667	17.00
MT 3 - MT 4	305 0668	25.00



Threading attachment M5 - M12

335 2042 299.00

- Integrated quick return traverse, immediately effective when changing the feed direction
- 4-stage adjustable friction clutch
- With holding fixture B16

Extent of supply

- 2 flexible collets · 2 flat wrenches · 1 Allen key



All prices with VAT excluded